

K2-1610 K-KL<sup>2</sup>-M

Montage an der Hauptschließkante/  
mounting on the main closing edge

## Stückliste / List of Parts



### Konsolensatz / bracket set:

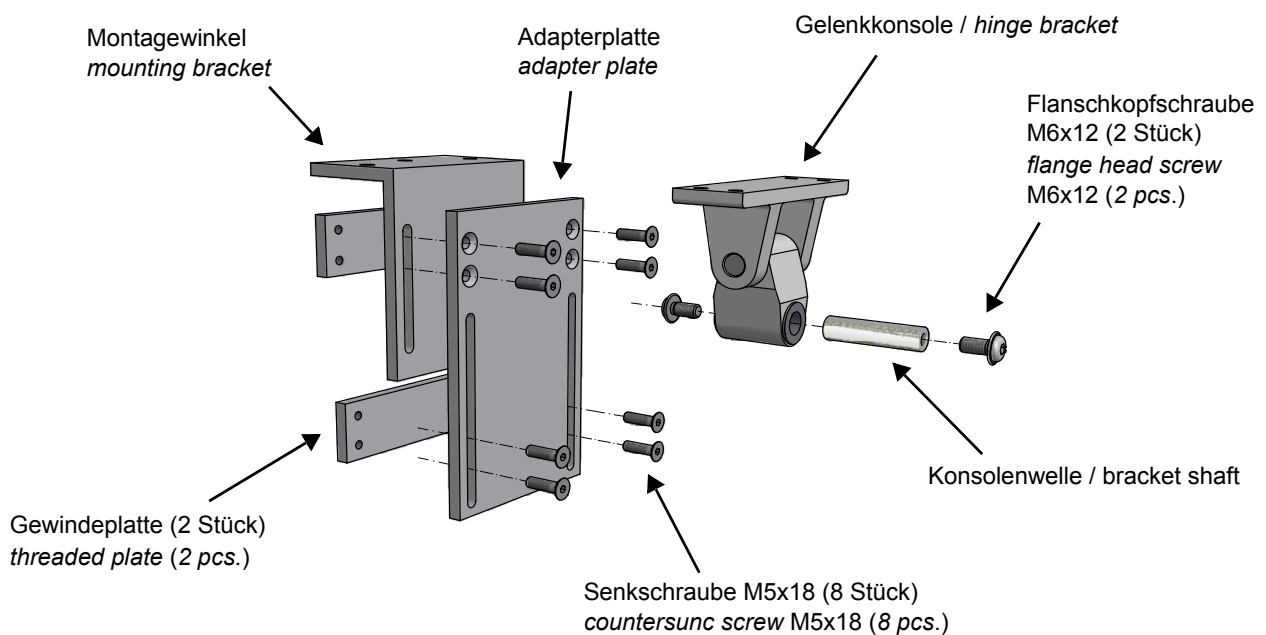

K2-1610 K-KL<sup>2</sup>-M

Montage an der Hauptschließkante/  
mounting on the main closing edge

## Montagehinweis / Instructions for Mounting

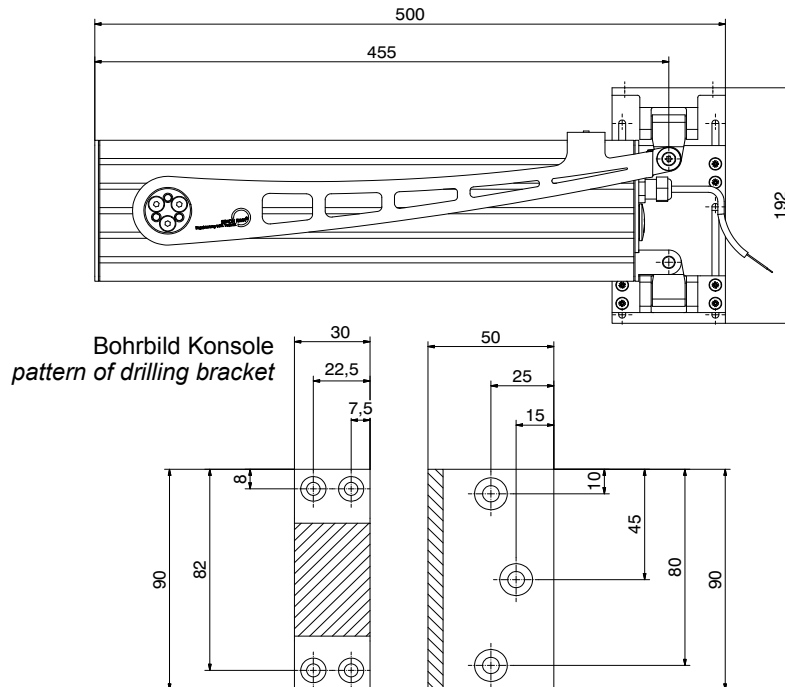

### ACHTUNG

Beachten Sie, dass die Montagewinkel parallel zur Hauptschließkante befestigt wird und in einem Abstand von 2 mm ( $\pm 1$  mm) von der Blendrahmenkante montiert werden muss.



### ATTENTION

Note that the angle bracket is fastened parallel to the main closing edge and must be mounted at a distance of 2 mm ( $\pm 1$  mm) from the wing edge.



### ACHTUNG

Beachten Sie, dass beim geschlossenen Fenster die Winkelkonsole und die Gelenkkonsole kardantisch in einer Flucht liegen!



### ATTENTION

Ensure that the angle bracket and the universal hinged bracket line up when the window is closed!

